

PROJECT NAME

AZURE

BASED ON
BOSS® CE-2 Chorus

EFFECT TYPE
Analog chorus

PROJECT SUMMARY

One of the most revered chorus pedals of all time, it uses analog BBDs to modulate the signal, resulting in the warm, rounded tone characteristic of this era.



BUILD DIFFICULTY

■■■■□ Intermediate

DOCUMENT VERSION

1.1.3 (2025-01-04)

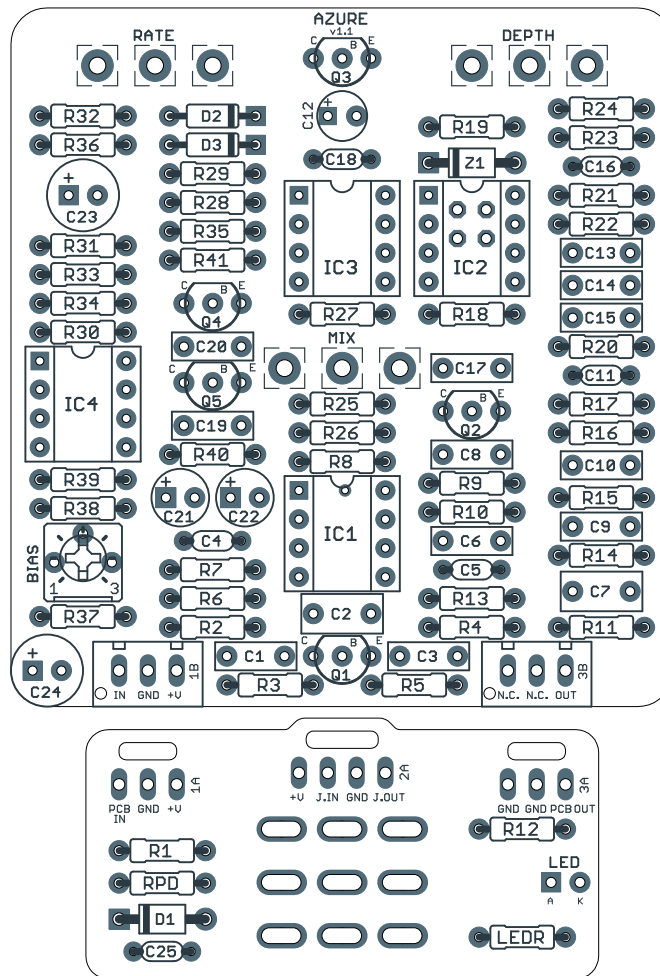

Actual size is 2.3" x 2.42" (main board) and 1.78" x 0.86" (bypass board).

IMPORTANT NOTE

This documentation is for the **PCB-only** version of the project. If you are building the full kit from Aion FX, please use the [kit build documentation](#) instead. The instructions are more detailed and may differ in some areas due to the specialized parts and assembly methods used in our kits.

TABLE OF CONTENTS

1	Project Overview	9	Drill Template
2	Introduction & Usage	10	Enclosure Layout
3-5	Parts List	11	Wiring Diagram
6-7	Build Notes	12	Licensing
8	Schematic	12	Document Revisions

INTRODUCTION

The Azure Analog Chorus is based on the BOSS® CE-2 Chorus Ensemble, first released in 1979 and generally considered to be one of the best chorus pedals ever made. With only two knobs, it's simple to operate, but it doesn't take long to understand the wide range of sounds contained inside.

The CE-2B Bass Chorus followed almost a decade later in 1987. It was the same basic circuit as the CE-2, but with one component in the audio path changed to make it better suited for bass, as well as the addition of a Mix knob to blend in the wet signal.

The Azure is based on the original CE-2, but it includes the mix knob from the CE-2B. With the mix knob all the way up, it's identical to the stock circuit, so this allows the intensity to be dialed back a bit while still preserving the originality. The full bass version can also be built with a single component substitution, covered in the parts list.

While the original CE-2 and CE-2B used the MN3007 BBD, the Azure can run on either the MN3007 or MN3207 (v3207) by setting some on-board jumpers. Since new BBD production has been slowed down significantly due to materials shortages, this flexibility makes it a little easier to find parts that will work.

USAGE

The Azure has three controls:

- **Rate** sets the speed of the chorus effect.
- **Depth** sets the intensity of the chorus effect.
- **Mix** adjusts the amount of modulated signal that is blended with the clean signal to create the chorus effect. This is especially useful for bass guitar so the low-end is preserved.

PARTS LIST

This parts list is also available in a spreadsheet format which can be imported directly into Mouser for easy parts ordering. Mouser doesn't carry all the parts—notably potentiometers—so the second tab lists all the non-Mouser parts as well as sources for each.

[View parts list spreadsheet](#) →

PART	VALUE	TYPE	NOTES
R1	1k	Metal film resistor, 1/4W	
R2	470k	Metal film resistor, 1/4W	
R3	10k	Metal film resistor, 1/4W	
R4	10k	Metal film resistor, 1/4W	
R5	47k	Metal film resistor, 1/4W	
R6	10k	Metal film resistor, 1/4W	
R7	47k	Metal film resistor, 1/4W	
R8	47k	Metal film resistor, 1/4W	
R9	47k	Metal film resistor, 1/4W	
R10	10k	Metal film resistor, 1/4W	
R11	470R	Metal film resistor, 1/4W	
R12	100k	Metal film resistor, 1/4W	
R13	100k	Metal film resistor, 1/4W	
R14	10k	Metal film resistor, 1/4W	
R15	10k	Metal film resistor, 1/4W	
R16	10k	Metal film resistor, 1/4W	
R17	10k	Metal film resistor, 1/4W	
R18	4k7	Metal film resistor, 1/4W	
R19	56k	Metal film resistor, 1/4W	
R20	330k	Metal film resistor, 1/4W	
R21	10k	Metal film resistor, 1/4W	
R22	10k	Metal film resistor, 1/4W	
R23	10k	Metal film resistor, 1/4W	
R24	10k	Metal film resistor, 1/4W	
R25	1M	Metal film resistor, 1/4W	
R26	47k	Metal film resistor, 1/4W	
R27	33k	Metal film resistor, 1/4W	
R28	2k7	Metal film resistor, 1/4W	
R29	150k	Metal film resistor, 1/4W	
R30	47k	Metal film resistor, 1/4W	
R31	33k	Metal film resistor, 1/4W	
R32	10k	Metal film resistor, 1/4W	

PARTS LIST, CONT.

PART	VALUE	TYPE	NOTES
R33	1M	Metal film resistor, 1/4W	
R34	220k	Metal film resistor, 1/4W	
R35	4k7	Metal film resistor, 1/4W	
R36	4k7	Metal film resistor, 1/4W	
R37	4k7	Metal film resistor, 1/4W	
R38	4k7	Metal film resistor, 1/4W	
R39	10k	Metal film resistor, 1/4W	
R40	10k	Metal film resistor, 1/4W	
R41	33R	Metal film resistor, 1/4W	
RPD	2M2	Metal film resistor, 1/4W	Input pulldown resistor. Can be as low as 1M.
LEDR	10k	Metal film resistor, 1/4W	LED current-limiting resistor. Adjust value to change LED brightness.
C1	47n	Film capacitor, 7.2 x 2.5mm	
C2	470n	Film capacitor, 7.2 x 3mm	
C3	6n8	Film capacitor, 7.2 x 2.5mm	
C4	100pF	MLCC capacitor, NP0/COG	
C5	100pF	MLCC capacitor, NP0/COG	
C6	6n8	Film capacitor, 7.2 x 2.5mm	
C7	1uF	Film capacitor, 7.2 x 3.5mm	
C8	33n	Film capacitor, 7.2 x 2.5mm	
C9	3n3	Film capacitor, 7.2 x 2.5mm	
C10	8n2	Film capacitor, 7.2 x 2.5mm	
C11	470pF	MLCC capacitor, NP0/COG	
C12	1uF	Tantalum capacitor, 044A	
C13	33n	Film capacitor, 7.2 x 2.5mm	
C14	3n3	Film capacitor, 7.2 x 2.5mm	
C15	8n2	Film capacitor, 7.2 x 2.5mm	
C16	470pF	MLCC capacitor, NP0/COG	
C17	33n	Film capacitor, 7.2 x 2.5mm	CE-2B (bass version) uses 12n here.
C18	47pF	MLCC capacitor, NP0/COG	
C19	100n	Film capacitor, 7.2 x 2.5mm	
C20	10n	Film capacitor, 7.2 x 2.5mm	
C21	47uF	Electrolytic capacitor, 5mm	Reference voltage filter capacitor.
C22	47uF	Electrolytic capacitor, 5mm	Reference voltage filter capacitor.
C23	220uF	Electrolytic capacitor, 6.3mm	Power supply filter capacitor.
C24	100uF	Electrolytic capacitor, 6.3mm	Power supply filter capacitor.
C25	100n	MLCC capacitor, X7R	Power supply filter capacitor.
Z1	1N4739A	Zener diode, 9.1V, DO-41	BBD protection diode. Use 1N4743 if using MN3007.

PARTS LIST, CONT.

PART	VALUE	TYPE	NOTES
D1	1N5817	Schottky diode, DO-41	
D2	1N914	Fast-switching diode, DO-35	
D3	1N914	Fast-switching diode, DO-35	
Q1	2N5088	BJT transistor, NPN, TO-92	Substitute. Original uses 2SC732TM-GR.
Q2	2N5088	BJT transistor, NPN, TO-92	Substitute. Original uses 2SC732TM-GR.
Q3	2N5088	BJT transistor, NPN, TO-92	Substitute. Original uses 2SC732TM-GR.
Q4	2N5088	BJT transistor, NPN, TO-92	Substitute. Original uses 2SC945P.
Q5	2N5088	BJT transistor, NPN, TO-92	Substitute. Original uses 2SC945P.
IC1	JRC4558D	Operational amplifier, DIP8	
IC1-S	DIP-8 socket	IC socket, DIP-8	
IC2	MN3207	Bucket-brigade delay, 1024 stages	The Coolaudio version of this chip is called the v3207.
IC2-S	DIP-8 socket	IC socket, DIP-8	
IC3	MN3102	Clock driver for BBD	The Coolaudio version of this chip is called the v3102.
IC3-S	DIP-8 socket	IC socket, DIP-8	
IC4	TL022	Operational amplifier, DIP8	
IC4-S	DIP-8 socket	IC socket, DIP-8	
BIAS	10k trimmer	Trimmer, 10%, 1/4"	Bourns 3362P or similar.
RATE	100kB	16mm right-angle PCB mount pot	
DEPTH	100kB	16mm right-angle PCB mount pot	
MIX	250kC	16mm right-angle PCB mount pot	
LED	5mm	LED, 5mm, red diffused	
IN	1/4" mono	1/4" phone jack, closed frame	Switchcraft 111X or equivalent.
OUT	1/4" mono	1/4" phone jack, closed frame	Switchcraft 111X or equivalent.
DC	2.1mm	DC jack, 2.1mm panel mount	Lumberg NEB/J 21 C or equivalent.
FSW	3PDT	Stomp switch, 3PDT	Available from Aion FX .
ENC	125B	Enclosure, die-cast aluminum	Can also use a Hammond 1590N1.

BUILD NOTES

BBD selection

The original bucket-brigade delay chips used in the CE-2 have been discontinued for many years and old-stock chips are getting difficult to find. Fortunately, reproductions of both the MN3007 and the newer MN3207 are available along with the corresponding clock driver, and they perform just as well as the original devices in this circuit.

The original CE-2 uses the [MN3007](#) (reproductions available from Xvive), while later chorus pedals such as the CE-3 use the MN3207 (reproductions available from Coolaudio as the [v3207](#)). The Azure project is set up to allow either type to be used by soldering two jumpers in one configuration or another.

So which should you use? The MN3207 has slightly better noise specs, but a lower maximum operating voltage. In this application, the maximum voltage doesn't make much of a difference since we're running it at 9V either way, so the added expense of the MN3007 probably outweighs any advantage.

Clock selection

The MN3101 clocks are only compatible with the MN3007, and the MN3102 and v3102 clocks are only compatible with the MN3207 and v3207.

In late 2023, Cabintech made a [discrete version of the MN3101](#) that acts as a drop-in replacement in DIP-8 format. These perform just as well as the originals, so it's recommended to use them in conjunction with the MN3007.

We do not recommend trying to source old-stock MN3101s due to the risk of fakes or damaged parts.

Setting the jumpers

Underneath IC2, there are four jumper pads arranged in a square pattern. The MN3007 and MN3207 have their positive and negative supply pins inverted from each other, so the jumpers need to be set to route the supply voltages to the correct pins.

The underside of the PCB has a legend on the silkscreen showing which way the jumpers should be soldered. If using a MN3007, both jumpers should go horizontally. If using a MN3207 or v3207, the jumpers should go vertically.

The MN3101 and MN3102 clock drivers have the supply pins reversed internally, so these two chips are cross-compatible and IC3 does not require any of its own jumpers.

Setting the bias by ear

The trimmer adjusts the bias voltage to get optimum performance from the BBD. Set the Depth and Mix knobs all the way up and set Rate to a low or medium speed, between 8:00 and 12:00. Start with the bias control at halfway, then adjust it up or down until you hear the strongest chorus and the least audible distortion.

BUILD NOTES, CONT.

Setting the bias with an oscilloscope

If you've got an oscilloscope, you can look at the waveform and fine-tune the bias visually rather than by ear. Connect the oscilloscope to the emitter of Q3 or the left leg of R24. Use a signal generator to create a sine wave at 200 Hz, 3V peak to peak, and send this to the pedal's input.

Set Depth and Mix all the way up and Rate somewhere between 8:00 and 12:00. Then, adjust the bias trimmer until the waveform is equally clipped on the top and bottom. The waveform is not symmetrical, so you're looking for equal-width clipping but not necessarily equal-shape clipping.

The CE-2 service manual says to use a test signal amplitude of +3dBm, which should convert to around 900mV peak to peak. However, in prototyping with a digital signal generator, we found that the amplitude needed to be significantly higher to get enough clipping that it could be reliably adjusted, which is why we've recommended 3V.

The test signal is intended to be much larger than what the pedal will deal with in normal use, so the waveform will not clip like this in practice. It's just easier to dial the symmetry this way.

Bass mod

The CE-2B only has one component difference from the standard CE-2. The output capacitor of the effect signal, C17, has been lowered from 33n to 12n in the bass version.

This cuts the bass EQ of the effect signal somewhat so that only the upper frequencies are modulated and the lower frequencies are left untouched. In other words, bass mode has less bass while guitar mode has more bass. This prevents the low frequencies from modulating in a way that would sound out of tune or dissonant in a band setting.

Depth/intensity mod

C18 can be changed from 47pF to 100pF to increase the maximum modulation depth or intensity.

v1.0 error fix

We made a very minor layout change to the footswitch PCB in August 2022 and inadvertently disconnected a trace on the main board in the process. This blocks the wet signal, so if this trace is missing then the pedal will pass dry signal but will not have any chorus effect.

Only a few dozen PCBs were affected, anything shipping between August and November of 2022. If your footswitch PCB has the extended slot above the +V/I/GND/O pads indicated on the right, but it does not say "AZURE v1.1" at the very top, then check and see if the trace from R17 connects to R18 or if there is a tiny gap between the pad and the trace, outlined in red in the upper diagram.

To fix this, just solder a jumper wire from the left pad of R17 to the right pad of R18 to make the connection.

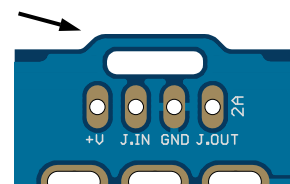
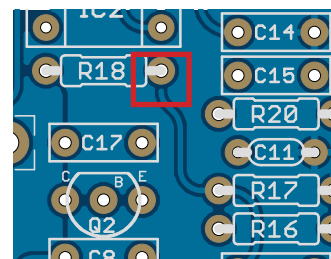

SCHEMATIC

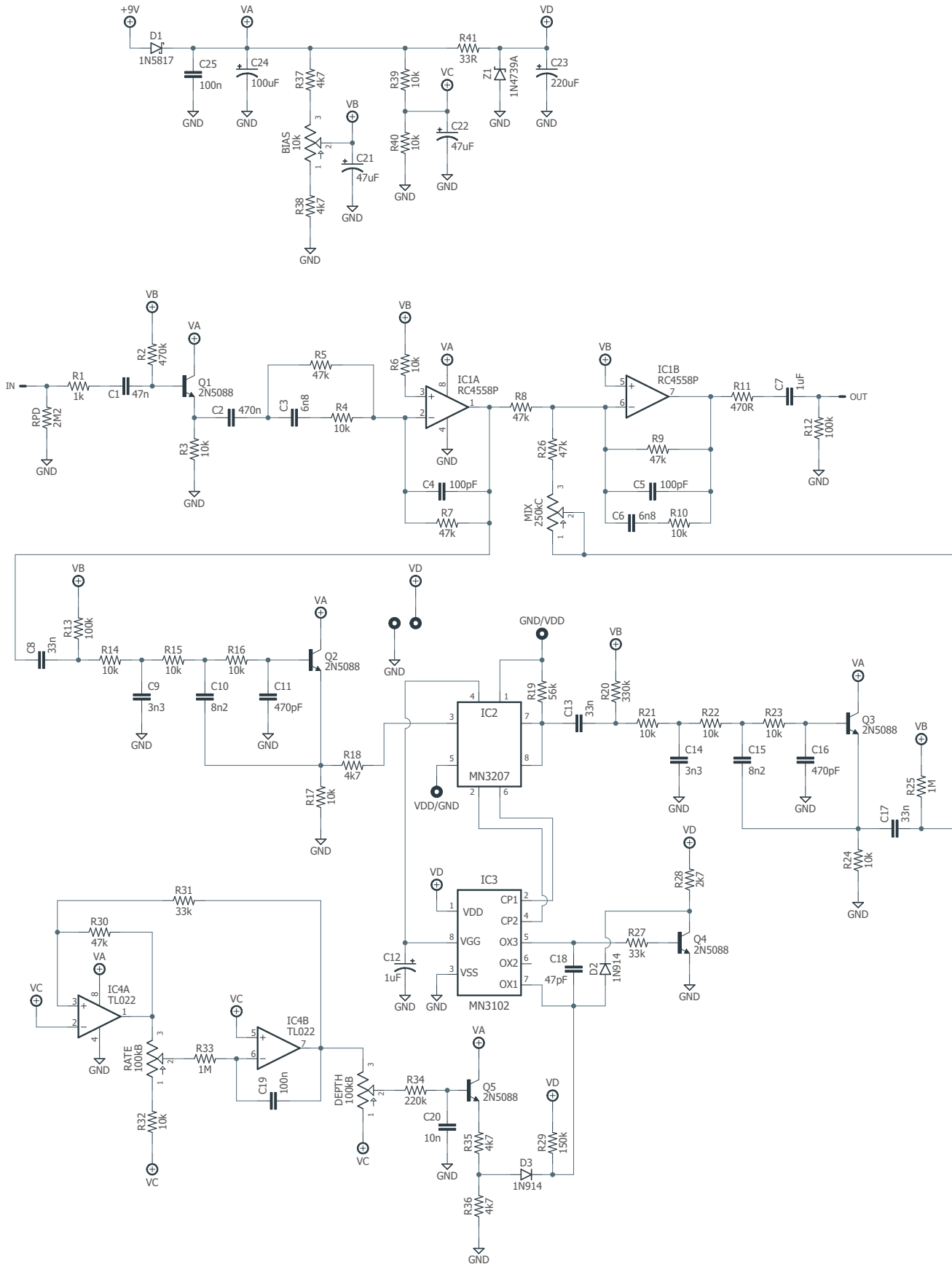

DRILL TEMPLATE

Cut out this drill template, fold the edges and tape it to the enclosure. Before drilling, it's recommended to first use a center punch for each of the holes to help guide the drill bit.

Ensure that this template is printed at 100% or "Actual Size". You can double-check this by measuring the scale on the printed page.

Top jack layout assumes the use of closed-frame jacks like the [Switchcraft 111X](#). If you'd rather use open-frame jacks, please refer to the [Open-Frame Jack Drill Template](#) for the top side.

LED hole drill size assumes the use of a [5mm LED bezel](#), available from several parts suppliers. Adjust size accordingly if using something different, such as a 3mm bezel, a plastic bezel, or just a plain LED.

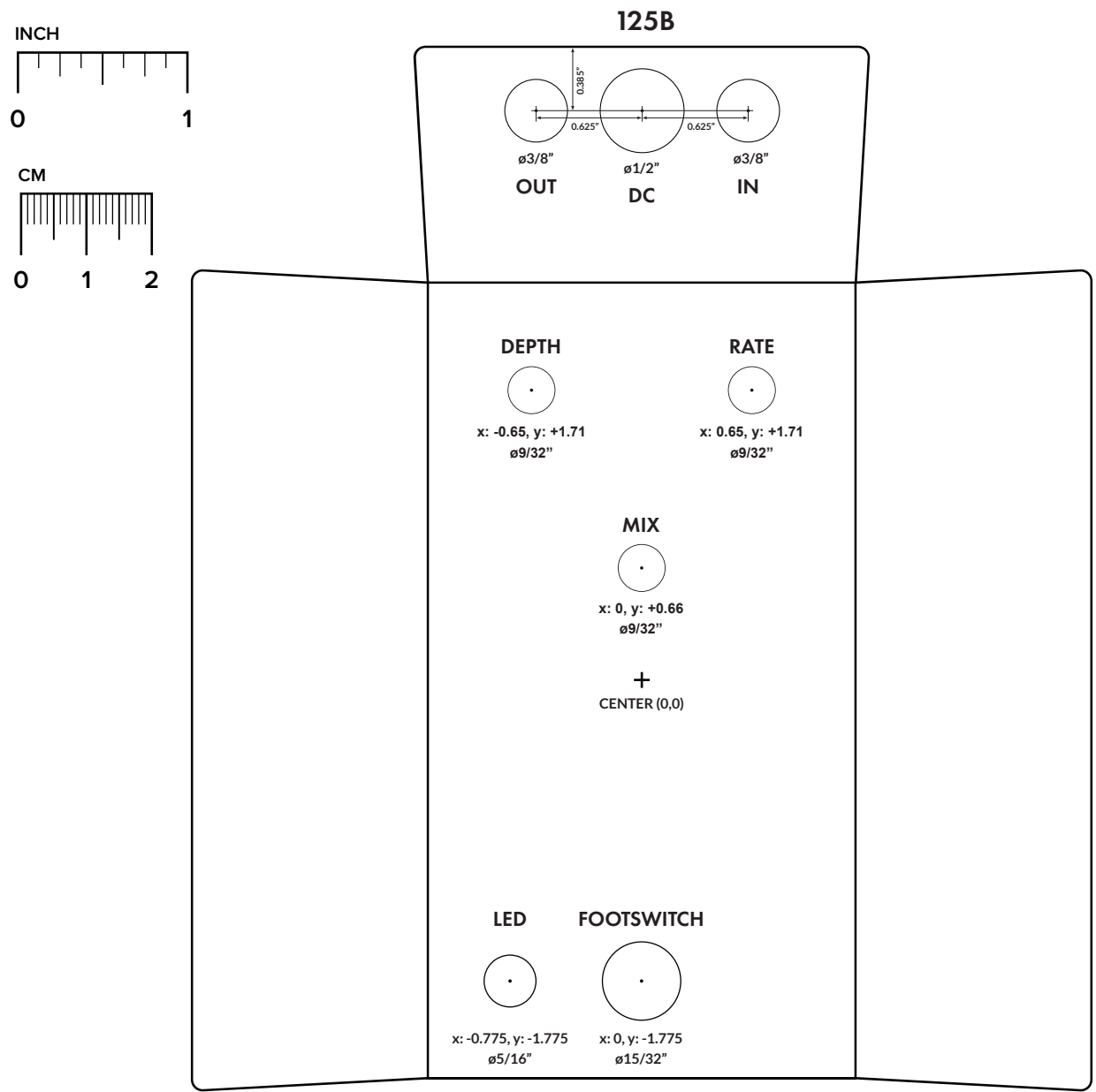

ENCLOSURE LAYOUT

Enclosure is shown without jacks. See next page for jack layout and wiring.

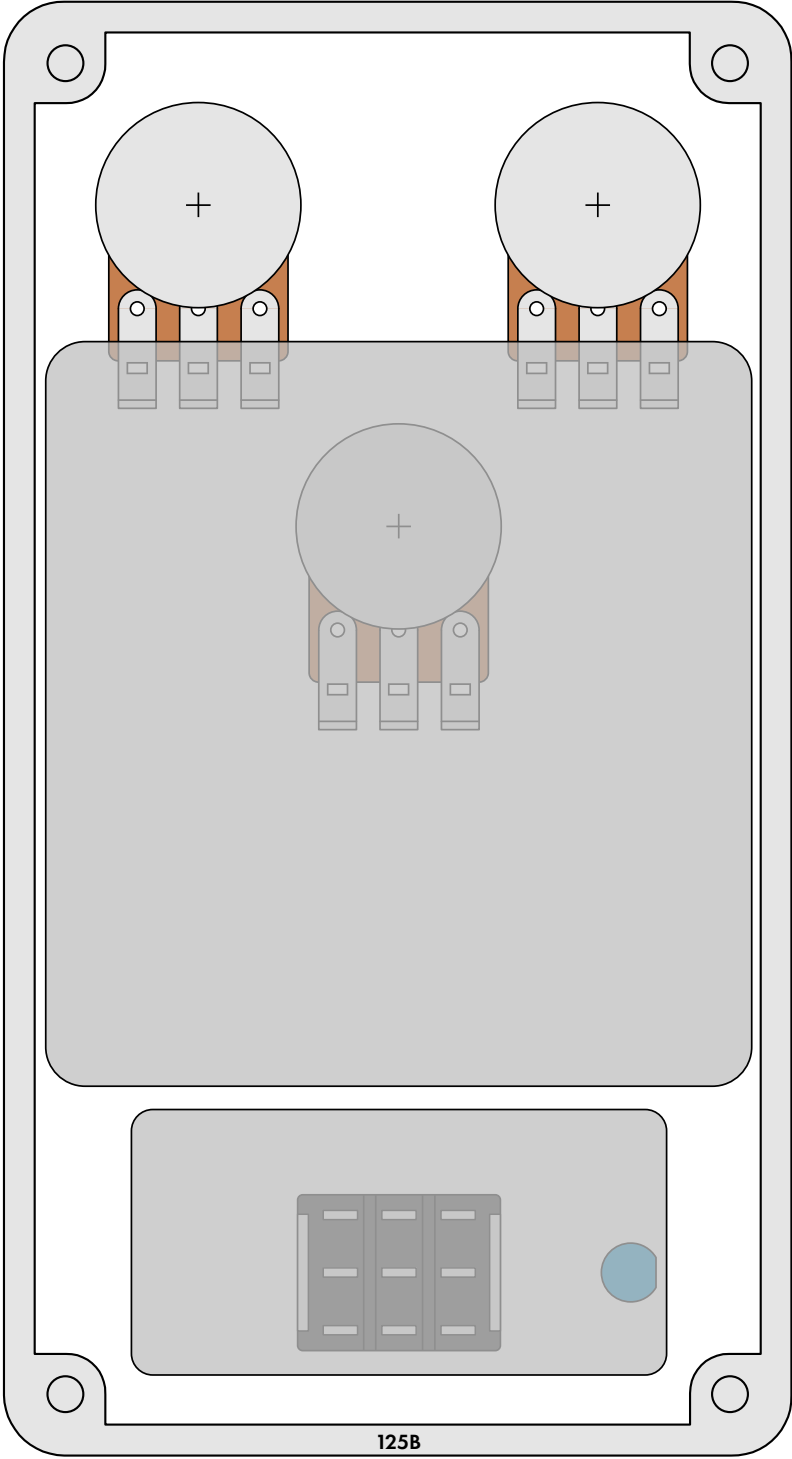

WIRING DIAGRAM

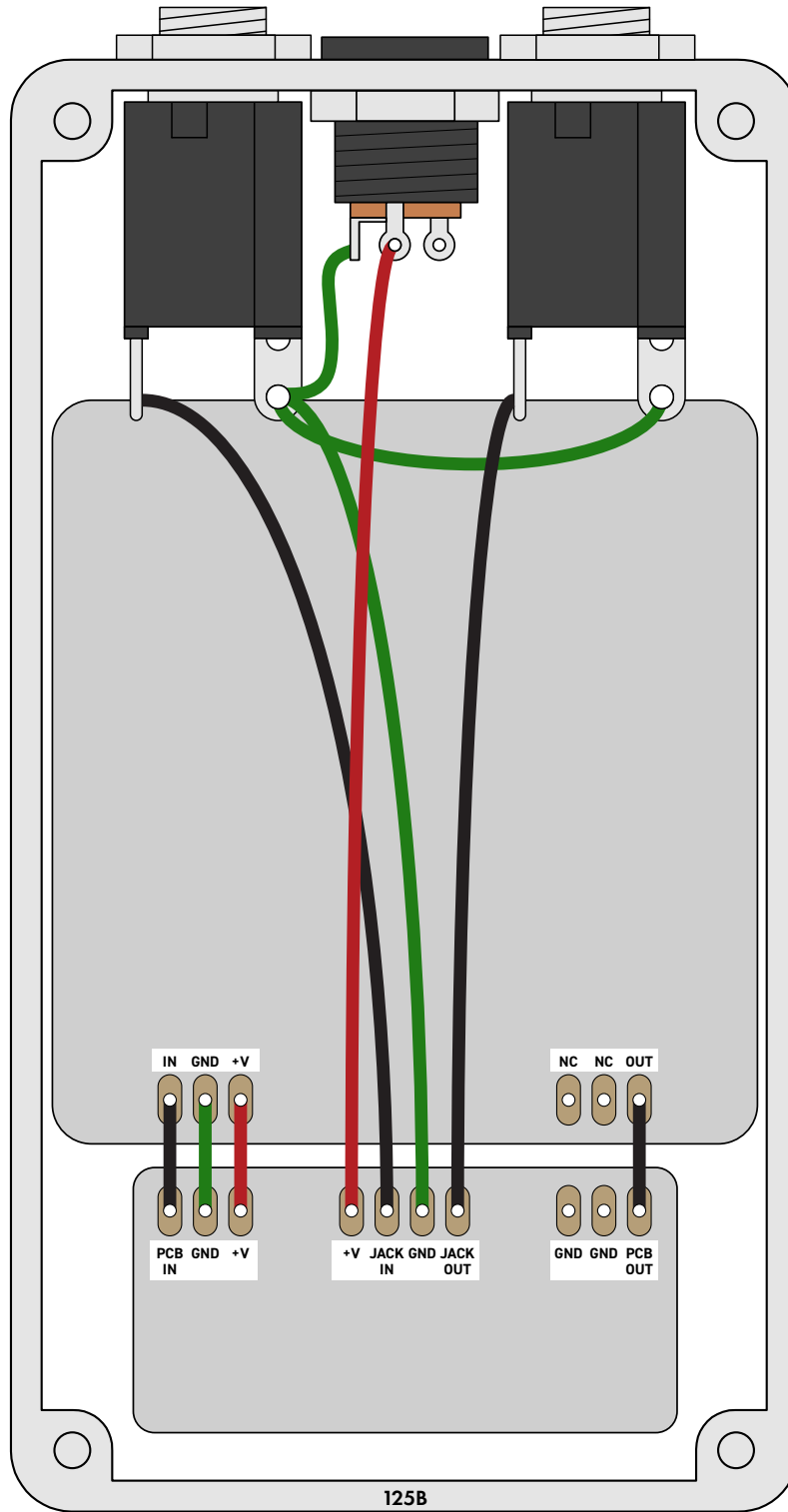

LICENSE & USAGE

No direct support is offered for these projects beyond the provided documentation. It's assumed that you have at least some experience building pedals before starting one of these. Replacements and refunds cannot be offered unless it can be shown that the circuit or documentation are in error.

All of these circuits have been tested in good faith in their base configurations. However, not all the modifications or variations have necessarily been tested. These are offered only as suggestions based on the experience and opinions of others.

Projects may be used for commercial endeavors in any quantity unless specifically noted. No attribution is necessary, though a link back is always greatly appreciated. The only usage restrictions are that **(1) you cannot resell the PCB as part of a kit without prior arrangement**, and **(2) you cannot "goop" the circuit, scratch off the screenprint, or otherwise obfuscate the circuit to disguise its source.** (In other words: you don't have to go out of your way to advertise the fact that you use these PCBs, but please don't go out of your way to hide it. The guitar effects industry needs more transparency, not less!)

DOCUMENT REVISIONS

1.1.3 (2025-01-04)

Minor revisions to the biasing procedure on pages 6-7.

1.1.2 (2024-08-08)

Changed LEDR to 10k to work with a wider variety of LEDs.

1.1.1 (2023-12-07)

Added RPD, R1 and R12 to the schematic. They were present on the PCB and parts list but the schematic omitted them.

1.1.0 (2022-12-08)

Error fix for approximately 40 PCBs that shipped between August and November 2022.

1.0.1 (2022-01-25)

Updated Z1 in schematic to 1N4739A (was 1N4738A). The parts list was correct.

1.0.0 (2021-11-26)

Initial release.