

PROJECT NAME

ARGUS

BASED ON

Roland® AD-50 Double Beat

BUILD DIFFICULTY

■■■■■ Easy

EFFECT TYPE

Fuzz

DOCUMENT VERSION

1.0.1 (2023-03-22)

PROJECT SUMMARY

An obscure silicon fuzz that originally comprised half of a fuzz-wah combination unit, featuring three unique “wave shape” tone modes.

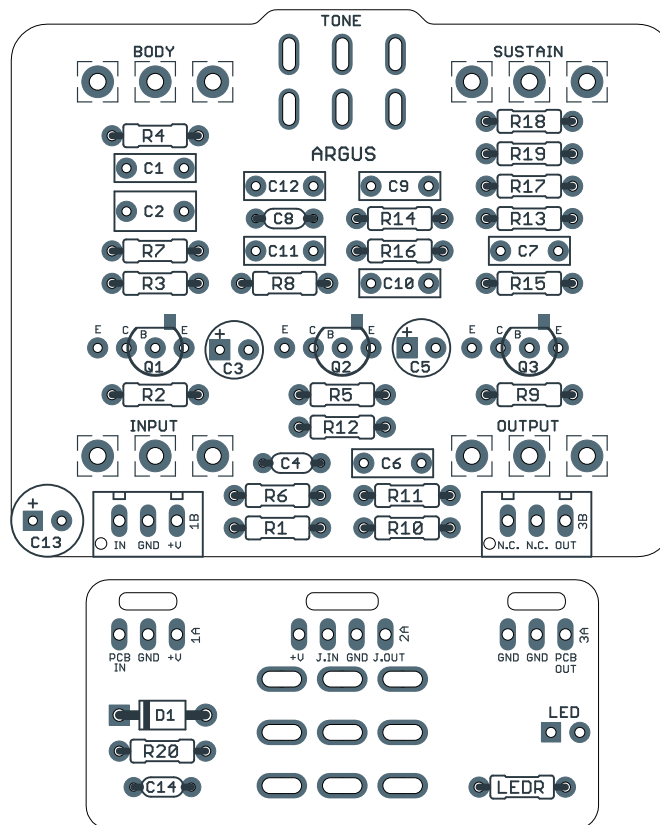

Actual size is 2.3" x 1.9" (main board) and 1.78" x 0.87" (bypass board).

TABLE OF CONTENTS

1	Project Overview	7	Drill Template
2	Introduction & Usage	8	Enclosure Layout
3-4	Parts List	9	Wiring Diagram
5	Build Notes	10	Licensing
6	Schematic	10	Document Revisions

INTRODUCTION

The Argus Silicon Fuzz is based on the fuzz section of the Roland AD-50 Double Beat, a combination fuzz-wah pedal originally released in 1973. The fuzz section is unique and was never released separately from the wah, though the fuzz and wah circuits are independent and fully functional on their own.

The main unique feature of the AD-50 fuzz is the 3-position “wave shape” selector. By filtering the signal in different ways, it can be transformed into a square wave, sine wave, or triangle wave. There is no tone control other than these three fixed modes.

This sounds interesting and unique until you understand a little about how wave shapes correspond to more traditional descriptions of signal characteristics. A square wave is full-frequency with heavy clipping and low dynamics—the classic fuzz tone, and the qualities that distinguish fuzz from overdrive or distortion. A sine wave is rounded and balanced, more like a natural instrument, midrange-focused without too much bass or treble. A triangle wave is piercing, brittle and treble-heavy.

In prototyping the AD-50, we found that the triangle (treble) mode was virtually unusable. (Check out some YouTube demos of the Double Beat if you want to hear it for yourself.) Because of this, the Argus has the option to trade out this mode for a mid-scoop with the center frequency around 1kHz, similar to a Big Muff with its tone control in the center position. It doesn't have a catchy waveshape description like the other two modes, but it's a whole lot more useful.

In addition, we've added two more controls: an Input level control (similar to turning down the volume knob on the guitar) and a Body control that blends between a small and large input capacitor, which sets the amount of bass going into the clipping stage. Together with the mid-scoop mode, it transforms the AD-50 into a much more versatile fuzz machine.

USAGE

The Argus has four controls and one toggle switch:

- **Input** is a volume control that precedes the effect, serving the same function as the guitar's volume control. Use in conjunction with Sustain to set the gain texture.
- **Body** blends between two input capacitors, allowing the bass to be dialed back from stock.
- **Sustain** controls the amount of gain in the first transistor stage.
- **Output** is the output volume of the effect.
- **Tone** (3-position toggle) selects between three different tone modes: Square, Sine, and Triangle (which can optionally be exchanged for a mid-scoop mode, described in the build notes).

PARTS LIST

This parts list is also available in a spreadsheet format which can be imported directly into Mouser for easy parts ordering. Mouser doesn't carry all the parts—notably potentiometers—so the second tab lists all the non-Mouser parts as well as sources for each.

[View parts list spreadsheet](#) →

PART	VALUE	TYPE	NOTES
R1	10k	Metal film resistor, 1/4W	
R2	820k	Metal film resistor, 1/4W	
R3	1k2	Metal film resistor, 1/4W	
R4	22k	Metal film resistor, 1/4W	
R5	2k2	Metal film resistor, 1/4W	
R6	120k	Metal film resistor, 1/4W	
R7	470k	Metal film resistor, 1/4W	
R8	22k	Metal film resistor, 1/4W	
R9	1M	Metal film resistor, 1/4W	
R10	220k	Metal film resistor, 1/4W	
R11	1k	Metal film resistor, 1/4W	
R12	22k	Metal film resistor, 1/4W	
R13	1M	Metal film resistor, 1/4W	
R14	4k7	Metal film resistor, 1/4W	Use 150k for stock triangle wave mode. See build notes.
R15	39k	Metal film resistor, 1/4W	Omit for stock triangle wave mode. See build notes.
R16	10k	Metal film resistor, 1/4W	Omit for stock triangle wave mode. See build notes.
R17	100k	Metal film resistor, 1/4W	Jumper for stock triangle wave mode. See build notes.
R18	330k	Metal film resistor, 1/4W	
R19	150k	Metal film resistor, 1/4W	
R20	100R	Metal film resistor, 1/4W	
LED R	4k7	Metal film resistor, 1/4W	LED current-limiting resistor. Adjust value to change LED brightness.
C1	4n7	Film capacitor, 7.2 x 2.5mm	
C2	100n	Film capacitor, 7.2 x 2.5mm	
C3	1uF	Electrolytic capacitor, 4mm	
C4	47pF	MLCC capacitor, NP0/C0G	
C5	1uF	Electrolytic capacitor, 4mm	
C6	10n	Film capacitor, 7.2 x 2.5mm	
C7	100n	Film capacitor, 7.2 x 2.5mm	
C8	470pF	MLCC capacitor, NP0/C0G	Omit for stock triangle wave mode. See build notes.
C9	3n3	Film capacitor, 7.2 x 2.5mm	Use 250pF for stock triangle wave mode. See build notes.

PARTS LIST, CONT.

PART	VALUE	TYPE	NOTES
C10	18n	Film capacitor, 7.2 x 2.5mm	Omit for stock triangle wave mode. See build notes.
C11	6n8	Film capacitor, 7.2 x 2.5mm	
C12	6n8	Film capacitor, 7.2 x 2.5mm	
C13	100uF	Electrolytic capacitor, 6.3mm	Power supply filter capacitor.
C14	100n	MLCC capacitor, X7R	Power supply filter capacitor.
D1	1N5817	Schottky diode, DO-41	
Q1	2N5088	BJT transistor, NPN, TO-92	Original uses 2SC1000-GR. 2N5088 will perform identically.
Q2	2N5088	BJT transistor, NPN, TO-92	Original uses 2SC1000-GR. 2N5088 will perform identically.
Q3	2N5088	BJT transistor, NPN, TO-92	Original uses 2SC1000-GR. 2N5088 will perform identically.
INPUT	500kA	16mm right-angle PCB mount pot	
BODY	500kC	16mm right-angle PCB mount pot	
SUST.	10kC	16mm right-angle PCB mount pot	
OUTPUT	50kA	16mm right-angle PCB mount pot	
TONE	DPDT on-on-on	Toggle switch, DPDT on-on-on	See build notes for correct switch configuration.
LED	5mm	LED, 5mm, red diffused	
IN	1/4" stereo	1/4" phone jack, closed frame	Switchcraft 112BX or equivalent.
OUT	1/4" mono	1/4" phone jack, closed frame	Switchcraft 111X or equivalent.
DC	2.1mm	DC jack, 2.1mm panel mount	Lumberg NEB/J 21 C or equivalent.
FSW	3PDT	Stomp switch, 3PDT	Available from Aion FX .
ENC	125B	Enclosure, die-cast aluminum	Can also use a Hammond 1590N1.

BUILD NOTES

Mid-scoop mode

The original AD-50 has three different wave shape modes: square, sine, and triangle. Trust the witness of everyone who has ever played an AD-50 that triangle mode is absolutely unlistenable.

It's possible that it had some interesting interaction with the wah effect that was paired in the original Double Beat—but even giving the Roland engineers the benefit of the doubt, when the fuzz circuit is used on its own, triangle mode is useless.

Because of this, when developing the Argus we decided to change things around a bit. We did a significant amount of SPICE simulation, testing and prototyping to arrive at a very worthy replacement for triangle-wave mode: a mid-scoop with a similar tone response to a Big Muff, not as severe as the Superfuzz or Hyper Fuzz, but a natural-sounding EQ that brings out the best qualities of the fuzz.

This is a permanent modification, so unless you use sockets, you'll have to commit to the third position as either triangle mode or mid-scoop mode. It's not easy to convert one to the other without a lot of desoldering.

If you follow the parts list on the previous pages, you'll have the mid-scoop mode. If you want to use the triangle-wave mode instead, here are the changes to make (also noted in the schematic):

- **R14:** 150k (mid-scoop is 4k7)
- **R15:** omit (mid-scoop mode is 39k)
- **R16:** omit (mid-scoop mode is 10k)
- **R17:** jumper (mid-scoop mode is 100k)
- **C8:** omit (mid-scoop mode is 470pF)
- **C9:** 250pF (mid-scoop mode is 3n3)
- **C10:** omit (mid-scoop mode is 18n)

Mode switch

The mode switch is a DPDT on-on-on toggle. For this type of switch, depending on the manufacturer, there are two different types of configurations for the center position, which are as follows:



The Argus requires the **Type 2** configuration, which is used by most major manufacturers such as Taiway. If you're considering a different brand, make sure to check the configuration of the center position.

Many of the on-on-on switches sold by Tayda or Love My Switches are Type 1 and will not work.

In addition, make sure you're using an on-*on*-on switch and not an on-*off*-on switch, which has the same appearance and also has 3 positions, but will not work in this circuit.

DRILL TEMPLATE

Cut out this drill template, fold the edges and tape it to the enclosure. Before drilling, it's recommended to first use a center punch for each of the holes to help guide the drill bit.

Ensure that this template is printed at 100% or "Actual Size". You can double-check this by measuring the scale on the printed page.

Top jack layout assumes the use of closed-frame jacks like the [Switchcraft 111X](#). If you'd rather use open-frame jacks, please refer to the [Open-Frame Jack Drill Template](#) for the top side.

LED hole drill size assumes the use of a [5mm LED bezel](#), available from several parts suppliers. Adjust size accordingly if using something different, such as a 3mm bezel, a plastic bezel, or just a plain LED.

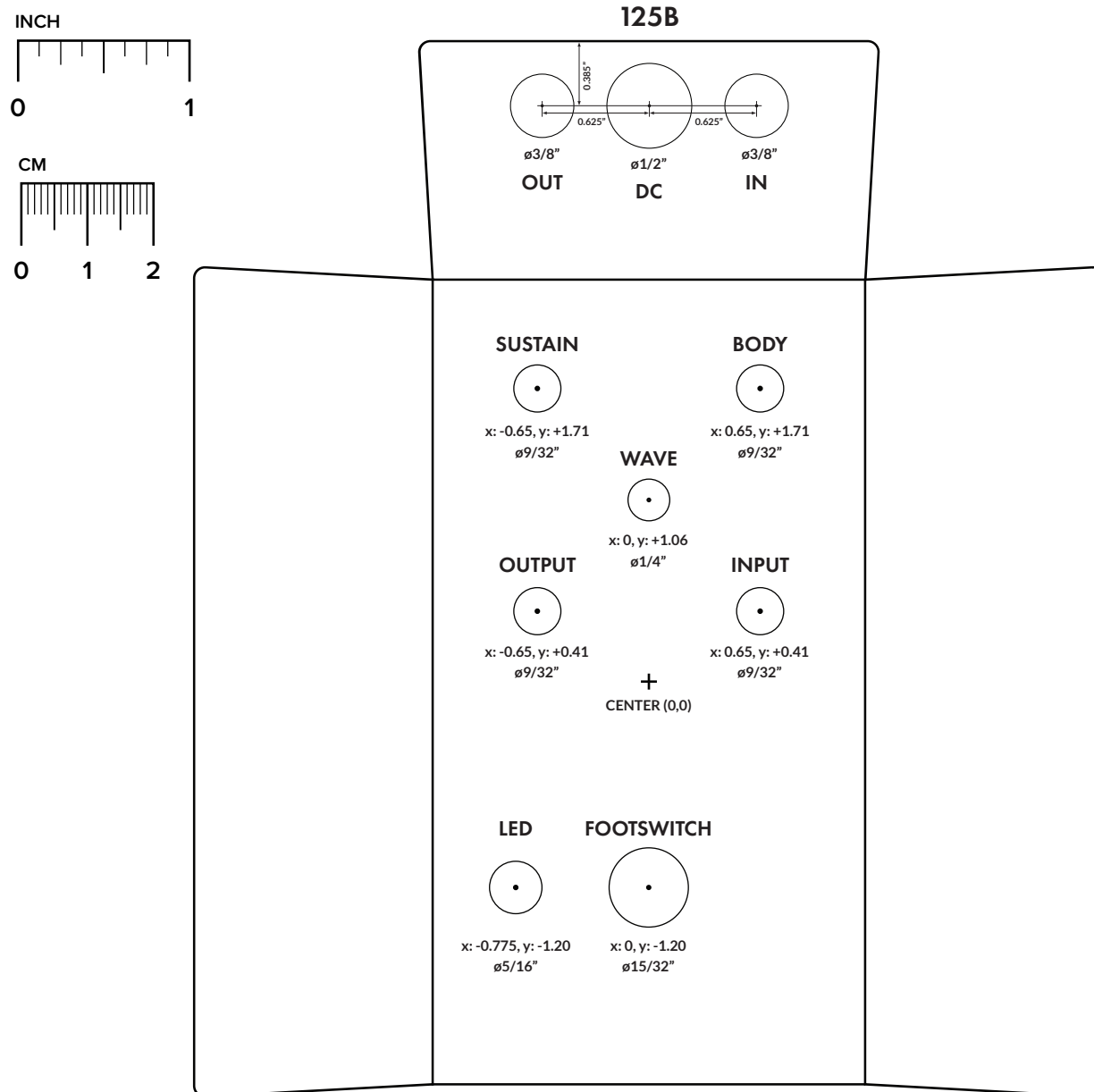

ENCLOSURE LAYOUT

Enclosure is shown without jacks. See next page for jack layout and wiring.

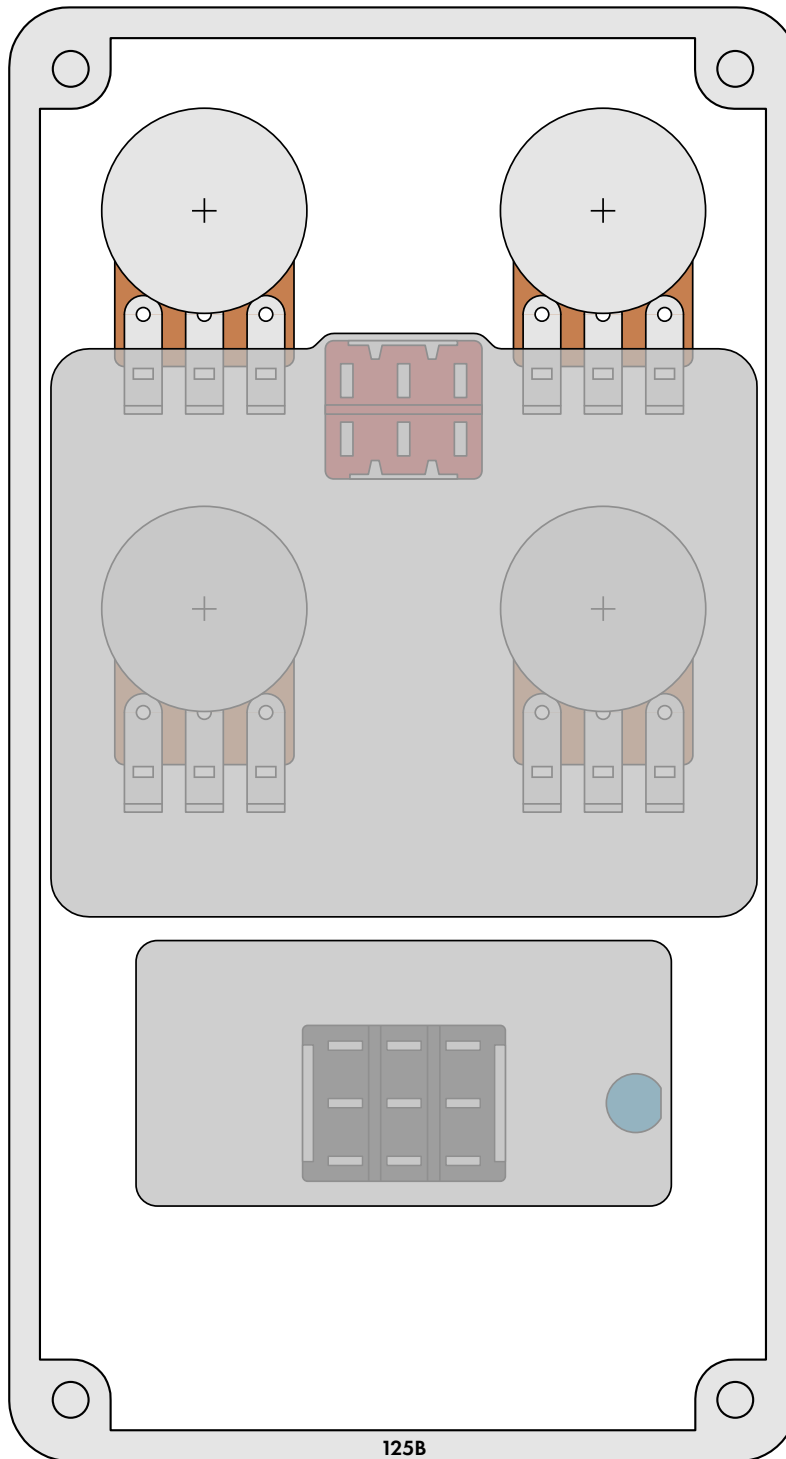

WIRING DIAGRAM

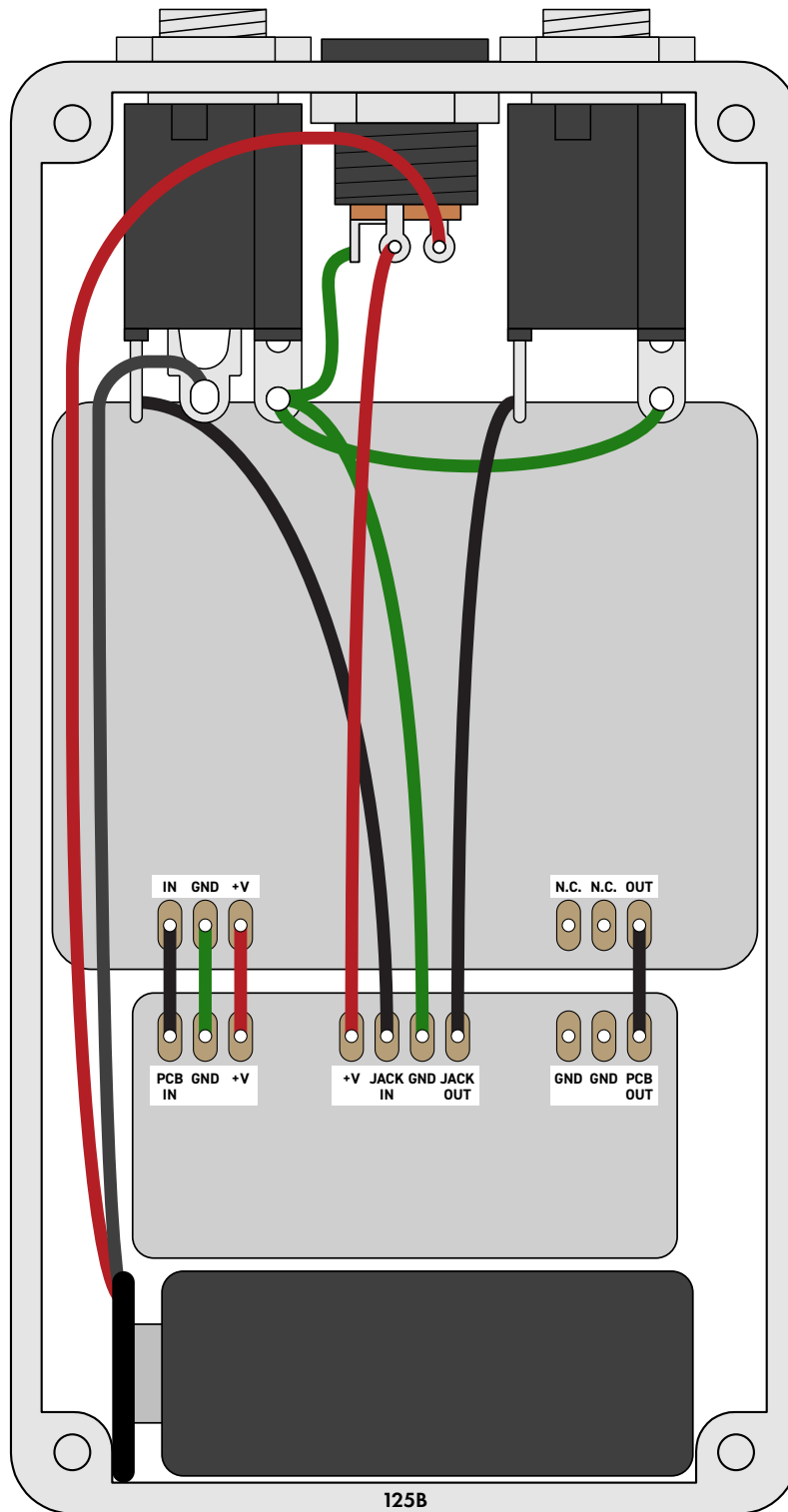

LICENSE & USAGE

No direct support is offered for these projects beyond the provided documentation. It's assumed that you have at least some experience building pedals before starting one of these. Replacements and refunds cannot be offered unless it can be shown that the circuit or documentation are in error.

All of these circuits have been tested in good faith in their base configurations. However, not all the modifications or variations have necessarily been tested. These are offered only as suggestions based on the experience and opinions of others.

Projects may be used for commercial endeavors in any quantity unless specifically noted. No attribution is necessary, though a link back is always greatly appreciated. The only usage restrictions are that **(1) you cannot resell the PCB as part of a kit without prior arrangement, and (2) you cannot "goop" the circuit, scratch off the screenprint, or otherwise obfuscate the circuit to disguise its source.** (In other words: you don't have to go out of your way to advertise the fact that you use these PCBs, but please don't go out of your way to hide it. The guitar effects industry needs more transparency, not less!)

DOCUMENT REVISIONS

1.0.1 (2023-03-22)

Clarified the type of DPDT switch to be used.

1.0.0 (2021-07-02)

Initial release.