

PROJECT NAME

424 PREAMP

BASED ON

Tascam 424

EFFECT TYPE

Distortion / EQ

BUILD DIFFICULTY

■□□□□ Beginner

DOCUMENT VERSION

1.0.0 (2025-03-28)



PROJECT SUMMARY

A pedal conversion of the input preamp of the Tascam 424 four-track tape recorder, most notably used by Mk.gee for his main drive tone.

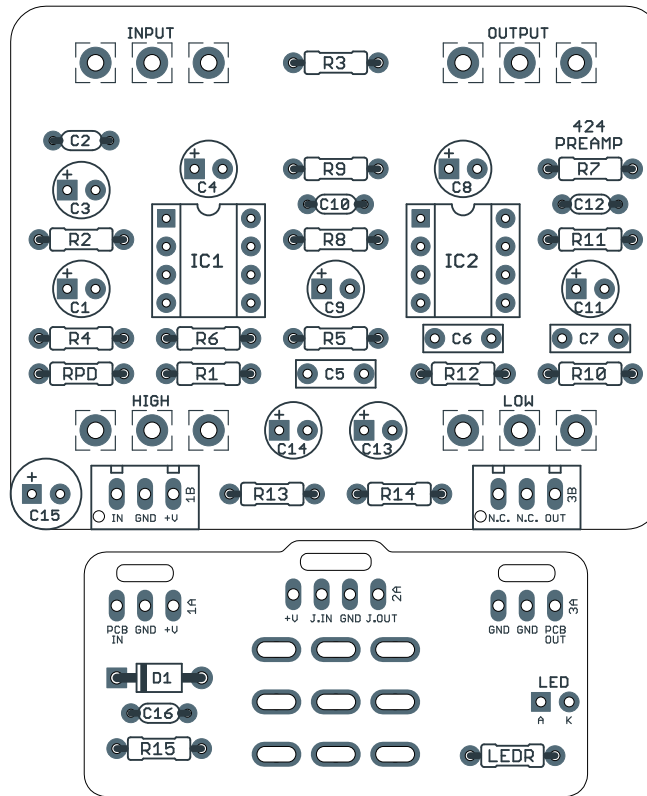

Actual size is 2.3" x 1.86" (main board) and 2.3" x 0.86" (bypass board).

TABLE OF CONTENTS

1	Project Overview	7	Drill Template
2	Introduction & Usage	8	Enclosure Layout
3-4	Parts List	9	Wiring Diagram
5	Schematic	10	Licensing
6	Build Notes	10	Document Revisions

INTRODUCTION

The 424 Tape Preamp replicates the dry audio path of one channel of the Tascam 424 Portastudio Mk. I, a 4-track tape recorder from the late 1980s to the early 1990s. While 4-track recorders have a long history of being misused to create interesting drive and distortion effects, the 424 in particular is one of the foundational pieces of Mk.gee's unique guitar tone.

The 424 Preamp has four knobs, each corresponding to a control on the original Tascam unit. The Input control is the equivalent of "Trim" on the Tascam, a potentiometer that cuts the input signal. It's intended to prevent clipping, but can be used to intentionally overload the op-amp stages as a drive control.

This is followed by a standard 2-band Baxandall EQ which boosts or cuts frequencies by +/-10dB, centered at 100 Hz and 10 kHz. The volume control is equivalent to the channel's "Master" slider. These are the only four controls that affect the audio signal; the slide switches only control the routing of the signal to the tape recorder or outboard effects.

The [Demo Tape Fuzz](#) by Mid-Fi Electronics (available as our [Torus](#) project) is a similar circuit that was also designed to sound like an overdriven tape recorder, and no doubt the Tascam was one of the inspirations for that circuit. But, the DTF is not based directly on any specific model as far as we know—so while it does capture the spirit and functionality, the 424 Preamp is actually an exact copy of what Mk.gee uses.

USAGE

The 424 Preamp has four controls:

- **Input** controls the signal level of the first op-amp stage. It acts as a drive control when the op-amp is intentionally overloaded at higher levels.
- **Low** and **High** form an active Baxandall tone control, which boosts or cuts at 100 Hz and 10kHz, with a flat response at the 12:00 position.
- **Output** controls the overall level at the output of the circuit.

PARTS LIST

This parts list is also available in a spreadsheet format which can be imported directly into Mouser for easy parts ordering. Mouser doesn't carry all the parts—notably potentiometers—so the second tab lists all the non-Mouser parts as well as sources for each.

[View parts list spreadsheet](#) →

PART	VALUE	TYPE	NOTES
R1	100k	Metal film resistor, 1/4W	
R2	470k	Metal film resistor, 1/4W	
R3	100R	Metal film resistor, 1/4W	
R4	10k	Metal film resistor, 1/4W	
R5	10k	Metal film resistor, 1/4W	
R6	22k	Metal film resistor, 1/4W	
R7	18k	Metal film resistor, 1/4W	
R8	5k6	Metal film resistor, 1/4W	
R9	470k	Metal film resistor, 1/4W	
R10	47k	Metal film resistor, 1/4W	
R11	110k	Metal film resistor, 1/4W	
R12	100k	Metal film resistor, 1/4W	
R13	10k	Metal film resistor, 1/4W	
R14	10k	Metal film resistor, 1/4W	
R15	47R	Metal film resistor, 1/4W	Power supply filter resistor.
RPD	2M2	Metal film resistor, 1/4W	Input pull-down resistor. Can be as low as 1M.
LED R	10k	Metal film resistor, 1/4W	LED current-limiting resistor. Adjust value to change LED brightness.
C1	10uF	Electrolytic capacitor, 5mm	
C2	100pF	MLCC capacitor, NP0/COG	
C3	10uF	Electrolytic capacitor, 5mm	
C4	10uF	Electrolytic capacitor, 5mm	
C5	1n8	Film capacitor, 7.2 x 2.5mm	
C6	15n	Film capacitor, 7.2 x 2.5mm	
C7	15n	Film capacitor, 7.2 x 2.5mm	
C8	10uF	Electrolytic capacitor, 5mm	
C9	10uF	Electrolytic capacitor, 5mm	
C10	47pF	MLCC capacitor, NP0/COG	
C11	10uF	Electrolytic capacitor, 5mm	
C12	10pF	MLCC capacitor, NP0/COG	
C13	10uF	Electrolytic capacitor, 5mm	
C14	47uF	Electrolytic capacitor, 5mm	Reference voltage filter capacitor.

PARTS LIST, CONT.

PART	VALUE	TYPE	NOTES
C15	100uF	Electrolytic capacitor, 6.3mm	Power supply filter capacitor.
C16	100n	MLCC capacitor, X7R	Power supply filter capacitor.
D1	1N5817	Schottky diode, DO-41	
IC1	LM833	Operational amplifier, dual, DIP8	
IC1-S	DIP-8 socket	IC socket, DIP-8	
IC2	NJM4565D	Operational amplifier, dual, DIP8	
IC2-S	DIP-8 socket	IC socket, DIP-8	
INPUT	10kC	16mm right-angle PCB mount pot	Reverse audio (antilog) taper.
OUTPUT	10kA	16mm right-angle PCB mount pot	Audio (log) taper.
HIGH	100kB	16mm right-angle PCB mount pot	Linear taper.
LOW	100kB	16mm right-angle PCB mount pot	Linear taper.
IN	1/4" stereo	1/4" phone jack, closed frame	Switchcraft 112BX or equivalent.
OUT	1/4" mono	1/4" phone jack, closed frame	Switchcraft 111X or equivalent.
LED	5mm	LED, 5mm, red diffused	
DC	2.1mm	DC jack, 2.1mm panel mount	Lumberg NEB/J 21 C or equivalent.
BATT	Battery snap	9V battery snap	Optional. Use the soft plastic type—the hard-shell type will not fit.
FSW	3PDT	Stomp switch, 3PDT	Available from Aion FX .
ENC	125B	Enclosure, die-cast aluminum	Can also use a Hammond 1590N1.

BUILD NOTES

IC selection

The original Tascam 424 uses the μ PC4570 for IC1. This IC is no longer available in through-hole DIP format, though old-stock parts can be found in small quantities.

However, the **LM833** is an exact replacement with identical specifications, so it's recommended to use this IC instead.

IC2 is an NJM4565, which is not commonly seen in guitar equipment but is still readily available from any part supplier such as Mouser.

Since the 424 circuit gets all of its clipping from overdriving the op-amps, it's strongly advised to keep to the ICs used in the original. Different op-amps will exhibit wildly different clipping characteristics.

SCHEMATIC

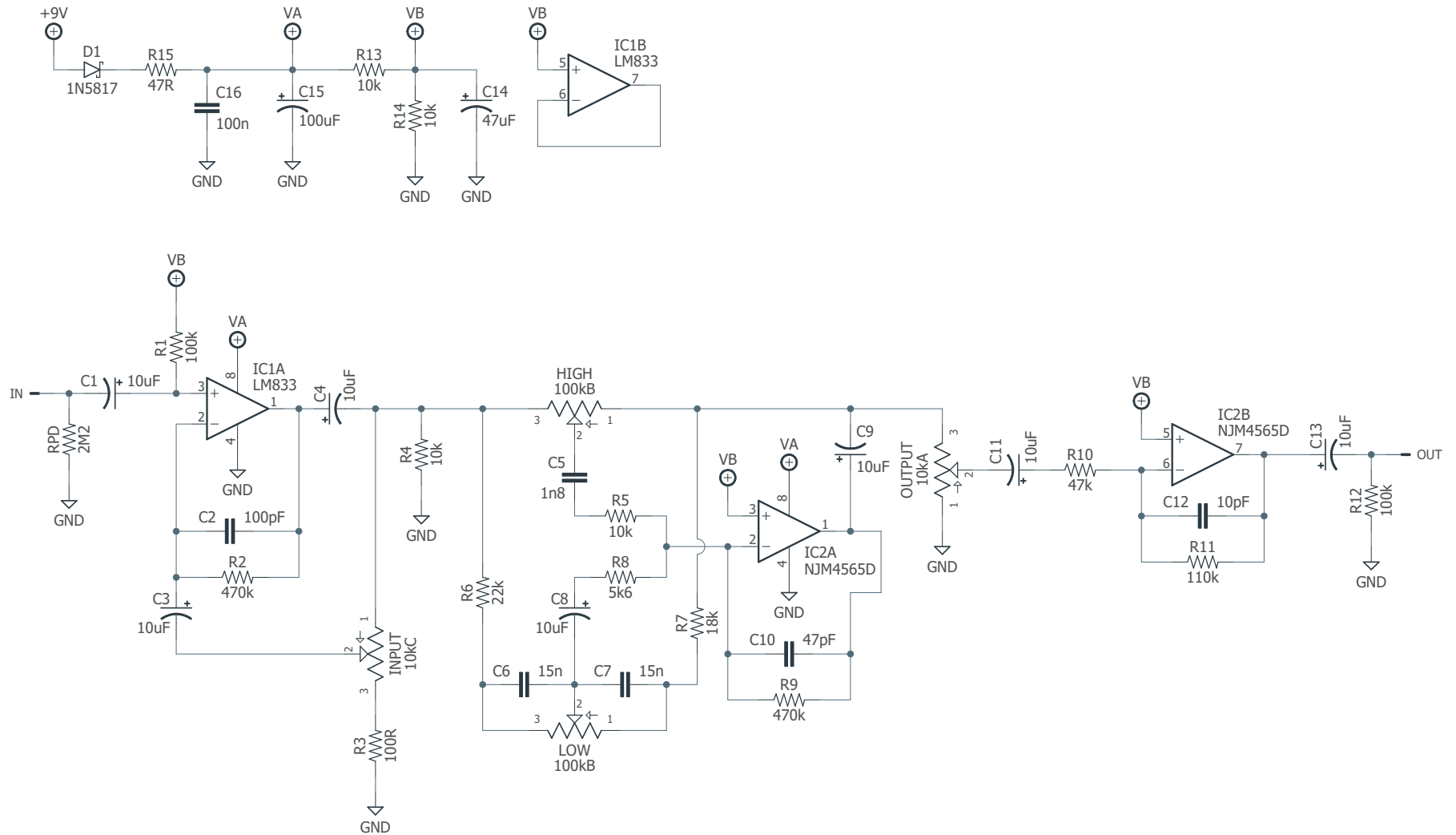

DRILL TEMPLATE

Cut out this drill template, fold the edges and tape it to the enclosure. Before drilling, it's recommended to first use a center punch for each of the holes to help guide the drill bit.

Ensure that this template is printed at 100% or "Actual Size". You can double-check this by measuring the scale on the printed page.

Top jack layout assumes the use of closed-frame jacks like the [Switchcraft 111X](#). If you'd rather use open-frame jacks, please refer to the [Open-Frame Jack Drill Template](#) for the top side.

LED hole drill size assumes the use of a [5mm LED bezel](#), available from several parts suppliers. Adjust size accordingly if using something different, such as a 3mm bezel, a plastic bezel, or just a plain LED.

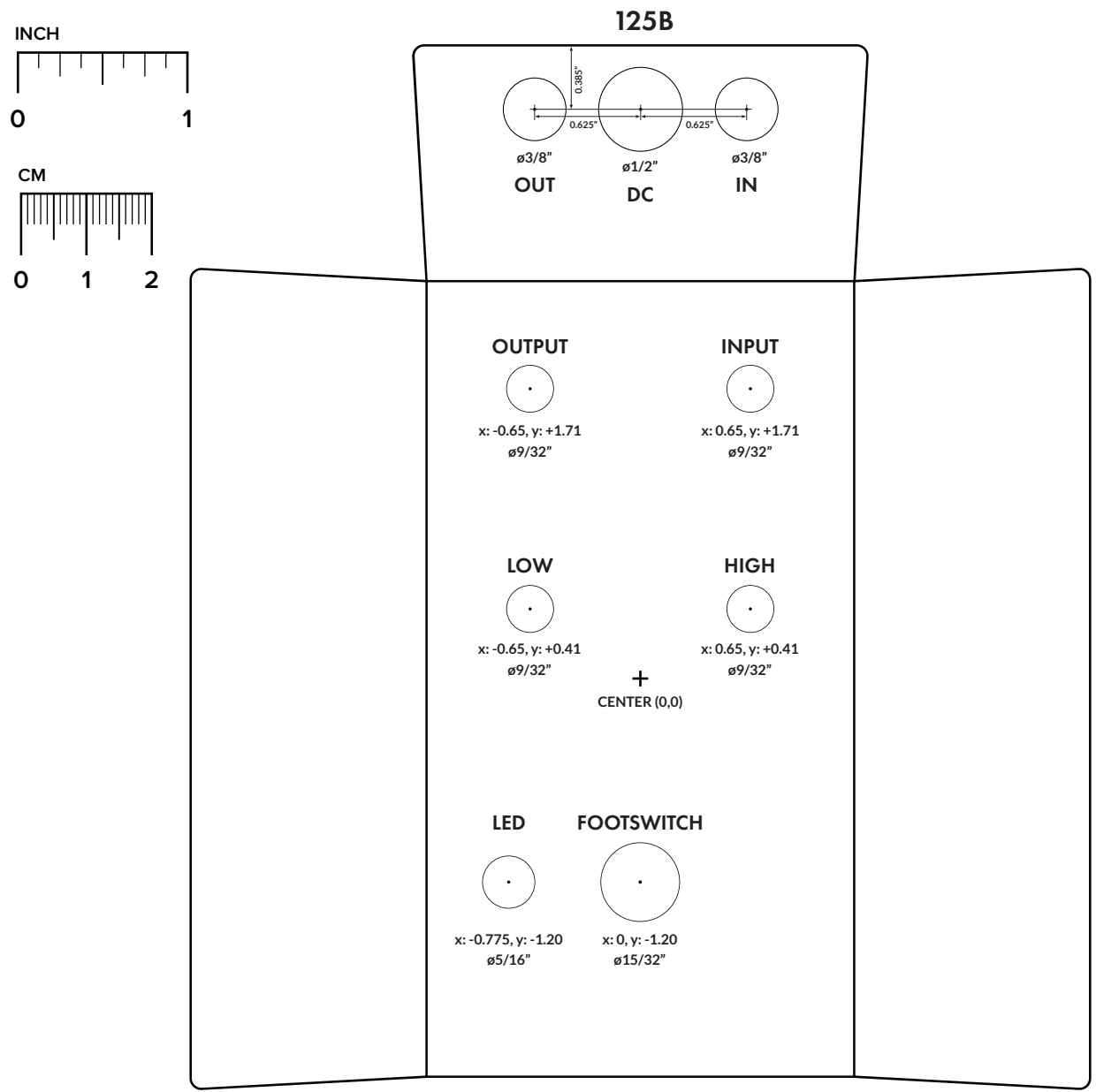

ENCLOSURE LAYOUT

Enclosure is shown without jacks. See next page for jack layout and wiring.

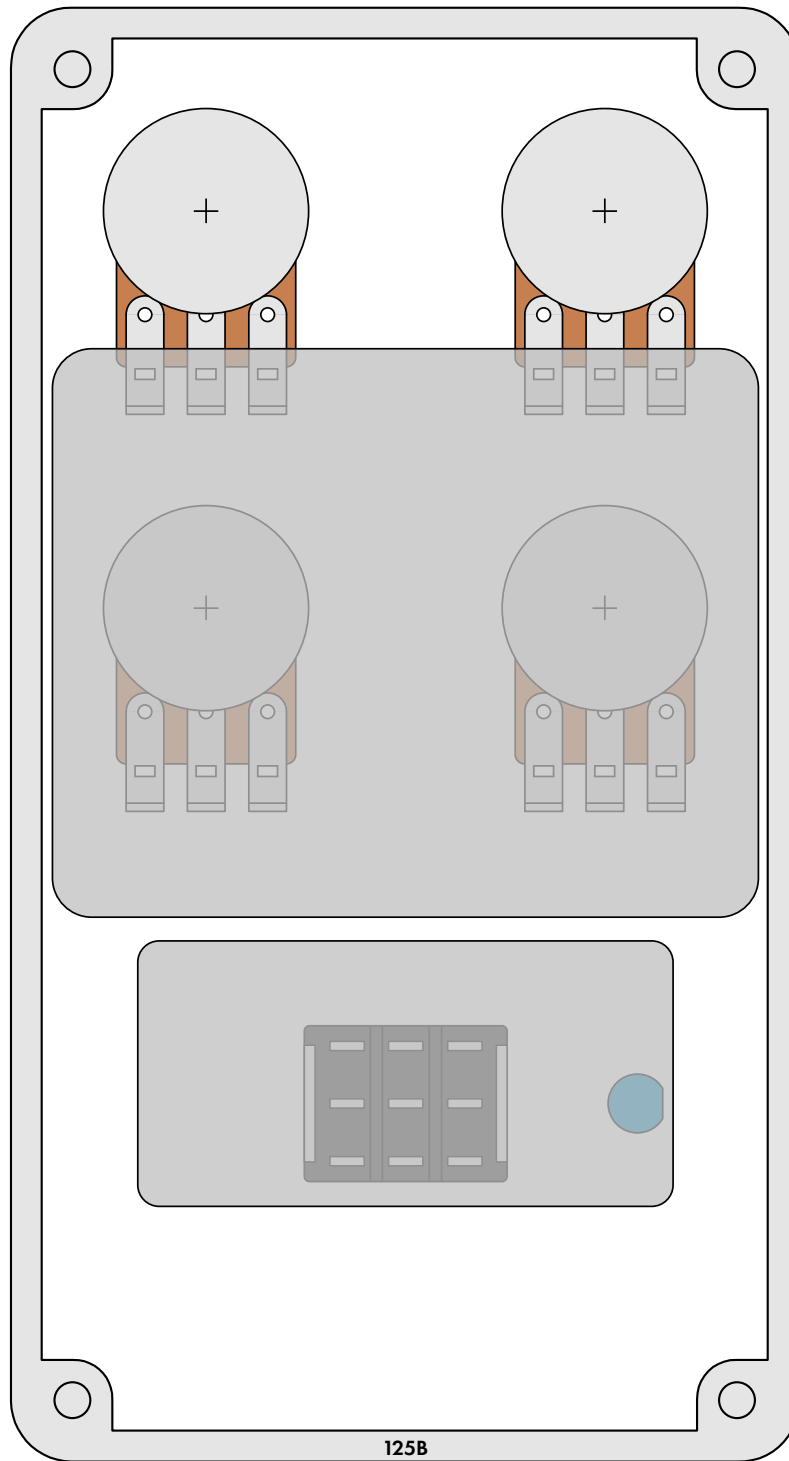

WIRING DIAGRAM

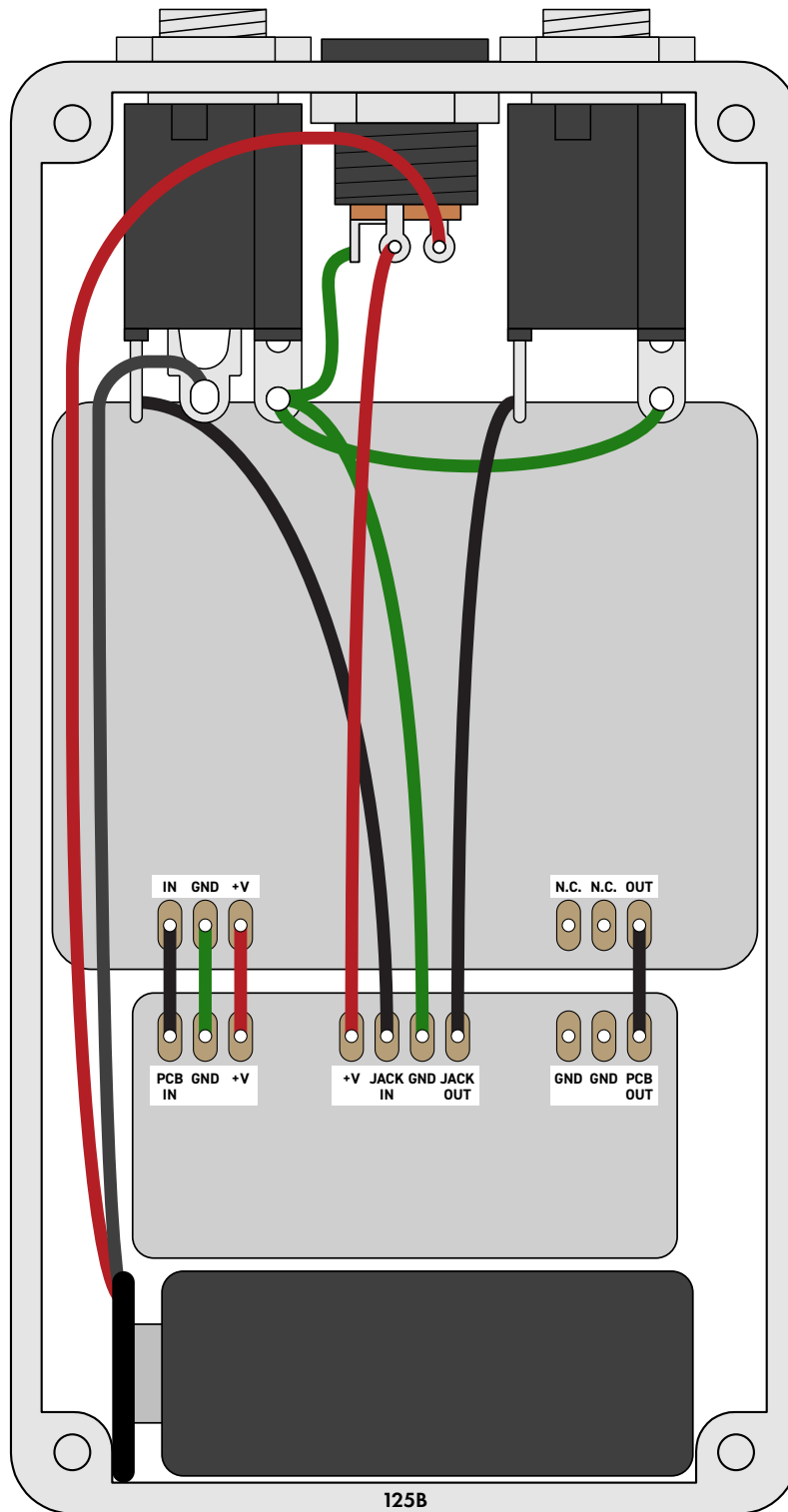

*Shown with optional 9V battery. If battery is omitted, both jacks can be mono rather than one being stereo.
Leave the far-right lug of the DC jack unconnected.*

LICENSE & USAGE

No direct support is offered for these projects beyond the provided documentation. It's assumed that you have at least some experience building pedals before starting one of these. Replacements and refunds cannot be offered unless it can be shown that the circuit or documentation are in error.

All of these circuits have been tested in good faith in their base configurations. However, not all the modifications or variations have necessarily been tested. These are offered only as suggestions based on the experience and opinions of others.

Projects may be used for commercial endeavors in any quantity unless specifically noted. No attribution is necessary, though a link back is always greatly appreciated. The only usage restrictions are that **(1) you cannot resell the PCB as part of a kit without prior arrangement, and (2) you cannot "goop" the circuit, scratch off the screenprint, or otherwise obfuscate the circuit to disguise its source.** (In other words: you don't have to go out of your way to advertise the fact that you use these PCBs, but please don't go out of your way to hide it. The guitar effects industry needs more transparency, not less!)

DOCUMENT REVISIONS

1.0.0 (2025-03-28)

Initial release.